

PRODUCT SHEET

# Slalom



**WOUD**

# Slalom step stool

Designed by Studio Dejawu

*The Slalom step stool is beautifully shaped by smoothly bent metal legs that embrace solid oak planks. Its minimalist form combines the sturdiness of the frame with the softness of the steps, which brings comfort and reliability to the design. With its portable nature, the Slalom step stool effortlessly serves as a helpful companion.*

## Year

2023

## Category / type

Seating / step stool

## Materials

Painted metal frame with solid oak steps

## Assembly instructions

Access the manual [here](#)

## Screws

Included

## Maximum recommended weight

160 kg

## Country of origin

China

## Packaging

No. of boxes: 1 box

L 460 x D 550 x H 190 mm

L 18.1 x D 21.6 x H 7.5"

## Weight

7,6 kg (8,6 kg incl. packaging)

## Care instructions

For daily care, wipe off with a clean, moist cloth followed by a soft dry cloth. All our recommended care guides can be downloaded [here](#).



## Item no / colour

110734 White pigmented lacquered oak and black painted metal

## Product dimensions

L 410 x D 410 x H 500 mm

L 16.1 x D 16.1 x H 19.7"

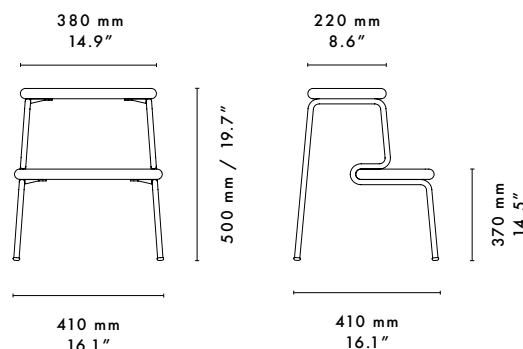

# Slalom step stool

Designed by Studio Dejawu

## English text

The Slalom step stool is beautifully shaped by smoothly bent metal legs that embrace solid oak planks. Its minimalist form combines the sturdiness of the frame with the softness of the steps, which brings comfort and reliability to the design. The silhouette of the stool is inspired by a skiing trip to northern Sweden, capturing the movement and dynamics of sinuous slalom traces carved into the snow.

With its portable nature, the Slalom step stool effortlessly serves as an assistant for reaching top shelves in the wardrobe, a companion for children in the kitchen or a convenient side table by the bed.

### Designed by Studio Dejawu

The Stockholm-based studio was founded by Qian Jiang in 2015. He describes his design process as akin to writing a diary, where he explores memories through experimental practices with materials, construction and finishes. With this approach he presents products in a narrative way, resulting in timeless and honest designs and art installations that tell a story and serve as a comprehensive source of inspiration.

## Danish text

Slalom skamlen er formet af et elegant, kurvede metalstel, der omfavner de massive egetræsplanker. Stellets enkle og stærke silhuet forenes på smuk vis med trinnenes bløde og afrundede form, hvilket skaber en balance mellem komfort og æstetik. Inspirationen til designet kommer fra en skitur til det nordlige Sverige og gengiver bevægelsen og dynamikken i de snoede slalomspor, der er skåret ind i sneen.

Med sin flytbare karakter fungerer Slalom skamlen ubesværet som en hjælper til at nå de øverste hylder i garderoben, som en tro følgesvend for børnene i køkkenet eller som et praktisk sidebord ved sengen.

### Designet af Studio Dejawu

Det Stockholms-baserede studie blev grundlagt af Qian Jiang i 2015. Han beskriver sin designproces som at skrive dagbog, hvor han udforsker minder gennem eksperimenter med materialer og konstruktion. Med denne tilgang præsenterer han produkter på en fortællende måde, hvilket resulterer i tidløse og ærlige design- og kunstinstallationer, der fortæller en historie.