

DEW

ASSEMBLY INSTRUCTION

W0UD

FORMED BY THE GLOWING ELLIPSOID
OPAL GLASS, RESTING ON A SOFT
SOLID WOOD TRAY, DEW IS A MULTI-
FUNCTIONAL OBJECT.
THE CONTEMPORARY LAMP SERVES
DIFFERENT PURPOSES WITH EASE.
WITH ITS PORTABLE AND DIMMABLE
FEATURES, DEW
IS IDEAL BOTH ON THE TABLE AND
THE WALL. YOU GET TO DECIDE.

SAIF FAISAL

TAKE CARE

**WE HAVE NOW HANDED OVER
ONE OF OUR DARLINGS TO YOU.
NOW IT IS YOURS. TAKE GOOD
CARE OF IT. YOU CAN READ THE
CARE INSTRUCTIONS FOR ALL
OUR MATERIALS AT OUR WEBSITE.**

WOU.DK/TAKECARE

ASSEMBLY INSTRUCTION

**PLEASE GO THROUGH THE FOLLOWING
STEPS CAREFULLY. RETAIN THIS MANUAL
FOR FUTURE REFERENCE TO ENSURE THAT
YOUR NEW ITEM IS CORRECTLY ASSEMBLED
IN CASE IT SHOULD BE DISASSEMBLED OR
MOVED. WE ARE NOT RESPONSIBLE FOR
ANY FAULTS OR DAMAGES CAUSED BY
NOT FOLLOWING THESE INSTRUCTIONS
CORRECTLY.**

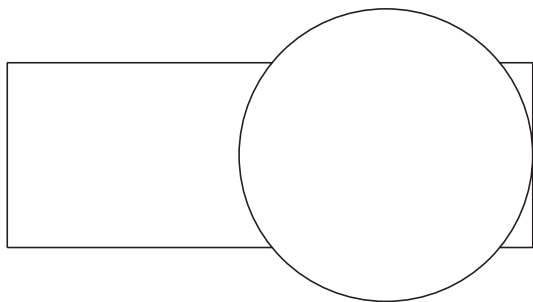

A x 1

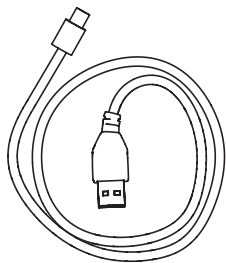

B x 1



c x 1

USB-C CONNECTOR SYSTEM

TOOLS NEEDED

THESE ITEMS ARE NOT INCL. AND CAN BE PURCHASED IN THE SHOPS.



1 X WALL
PLUGS
NOT INCL.

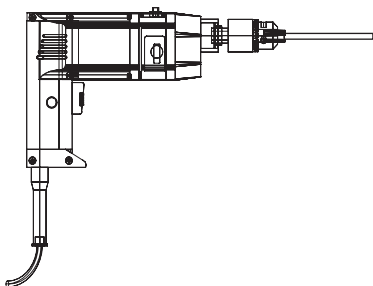

STEP 1

PLACE THE LAMP ON A TABLE, THEN INSERT THE USB-C CONNECTOR
AND CHARGE BEFORE USE.

CHARGE TIME = 5-7 HOURS & WORK TIME = 6-8 HOURS

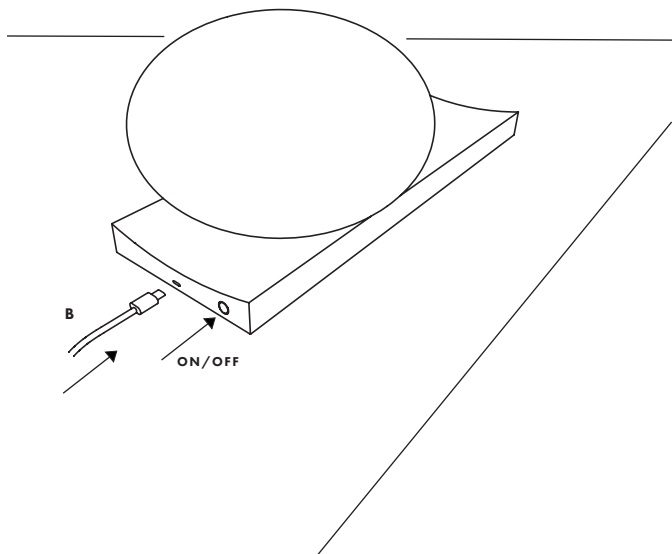

STEP 2

WHEN WALL MOUNTING THE LAMP - USE A PENCIL TO MARK A
PLACEMENT THEN DRILL THE HOLE AND APPLY A SUITABLE WALL PLUG.
USE THE SCREW AND SCREW IT IN THE WALL WITH A SCREWDRIVER.

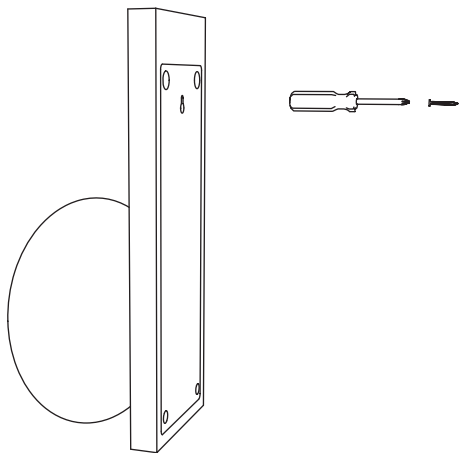

STEP 3

ENJOY THE LAMP HANGING ON THE WALL OR PLACE IT ON A TABLE.

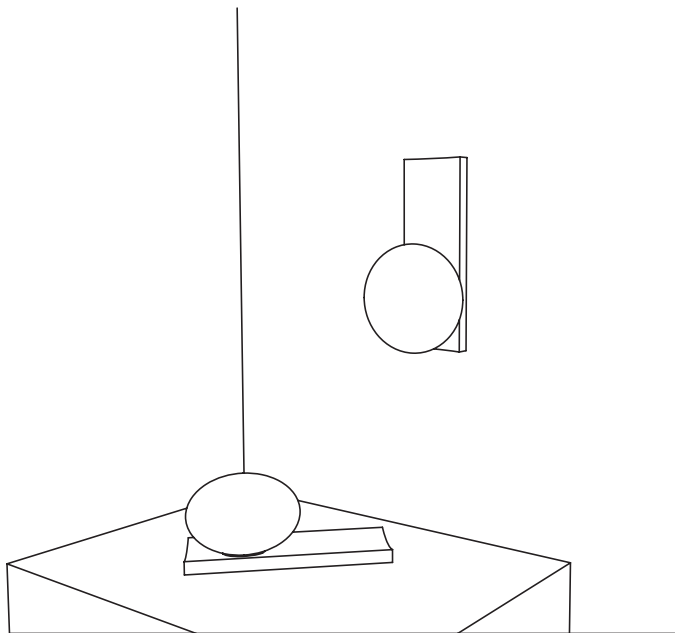

SAFETY INSTRUCTIONS



THE LAMP IS ONLY INTENDED FOR INTERIOR USE.

LAMP EXTERIOR CAN GET HOT AFTER PROLONGED USE.

PROTECT FROM CONTACT WITH LIQUIDS.

DO NOT PLACE THE CABLE IN REACH OF SMALL CHILDREN OR ANYWHERE THERE IS A RISK OF FALLING OVER IT.

SAFETY PRECAUTIONS

DK - SIKKERHEDSFORANSTALTNINGER HVIS LAMPENS UDVENDIGE LEDNING BLIVER BESKADIGET SKAL DER, FOR AT UNGDÅ EN FARLIG SITUATION, RETTES HENVENDELSE TIL PRODUCENTEN, SERVICE AGENTEN ELLER ANDEN LIGNENDE KVALIFICERET PERSON FOR UDSKIFTNING AF DENNE. PÆREN I DENNE LAMPE KAN IKKE UDSKIFTES. NÅR PÆREN IKKE LÆNGERE FUNGERER, SKAL HELE LAMPEN UDSKIFTES.

UK - SAFETY PRECAUTIONS IF THE EXTERNAL FLEXIBLE CABLE OR CORD OF THIS LUMINAIRE IS DAMAGED, IT SHALL BE EXCLUSIVELY REPLACED BY THE MANUFACTURER OR HIS SERVICE AGENT OR A SIMILAR QUALIFIED PERSON IN ORDER TO AVOID A HAZARD. THE LIGHT SOURCE OF THIS LUMINAIRE IS NOT REPLACEABLE; WHEN THE LIGHT SOURCE REACHES ITS END OF LIFE THE WHOLE LUMINAIRE SHALL BE REPLACED.

F - PRÉCAUTIONS DE SÉCURITÉ SI LE CÂBLE OU LE CORDON FLEXIBLE EXTERNE DE CE LUMINAIRE EST ENDOMMAGÉ, IL DOIT ÊTRE REMPLACÉ EXCLUSIVEMENT PAR LE FABRICANT, SON AGENT DE SERVICE OU UNE PERSONNE QUALIFIÉE SIMILAIRE AFIN D'ÉVITER TOUT DANGER. LA SOURCE LUMINEUSE DE CE LUMINAIRE N'EST PAS REMPLAÇABLE ; LORSQUE LA SOURCE LUMINEUSE ATTEINT SA FIN DE VIE, LE LUMINAIRE ENTIER DOIT ÊTRE REMPLACÉ.

E - MEDIDAS DE SEGURIDAD SI EL CABLE EXTERNO O CORDÓN DE ESTA LUMINARIA ES DAÑADO, DEBERÁ SER REEMPLAZADO EXCLUSIVAMENTE POR EL FABRICANTE, SU AGENTE COMERCIAL O PERSONA CUALIFICADA SIMILAR PARA EVITAR CUALQUIER PELIGRO. LA FUENTE DE LUZ DE ESTA LUMINARIA NO ES REEMPLAZABLE. CUANDO ÉSTA LLEGUE AL FINAL DE SU VIDA ÚTIL, LA ILUMINARIA DEBE REEMPLAZARSE POR COMPLETO.

D - SICHERHEITSVORKEHRUNGEN WENN DAS ÄUSSERE FLEXIBLE KABEL ODER DIE SCHNUR DIESER LEUCHE BESCHÄDIGT IST, DARF NUR DER HERSTELLER ODER SEIN KUNDENDIENST ODER EINE ÄHNLICH QUALIFIZIERTE PERSON DAS KABEL ERSETZEN, UM EINE GEFÄHRDUNG ZU VERMEIDEN. DIE LICHTQUELLE DIESER LEUCHE IST NICHT ERSETZBAR; WENN DIE LICHTQUELLE DAS ENDE IHRER LEBENSDAUER ERREICHT, MUSS DIE GESAMTE LEUCHE ERSETZT WERDEN.